

Austrong Products

ALUMINUM SUN LOUVER ASC P150
LAM CHẮN NẮNG CÁNH CUNG ASC P150

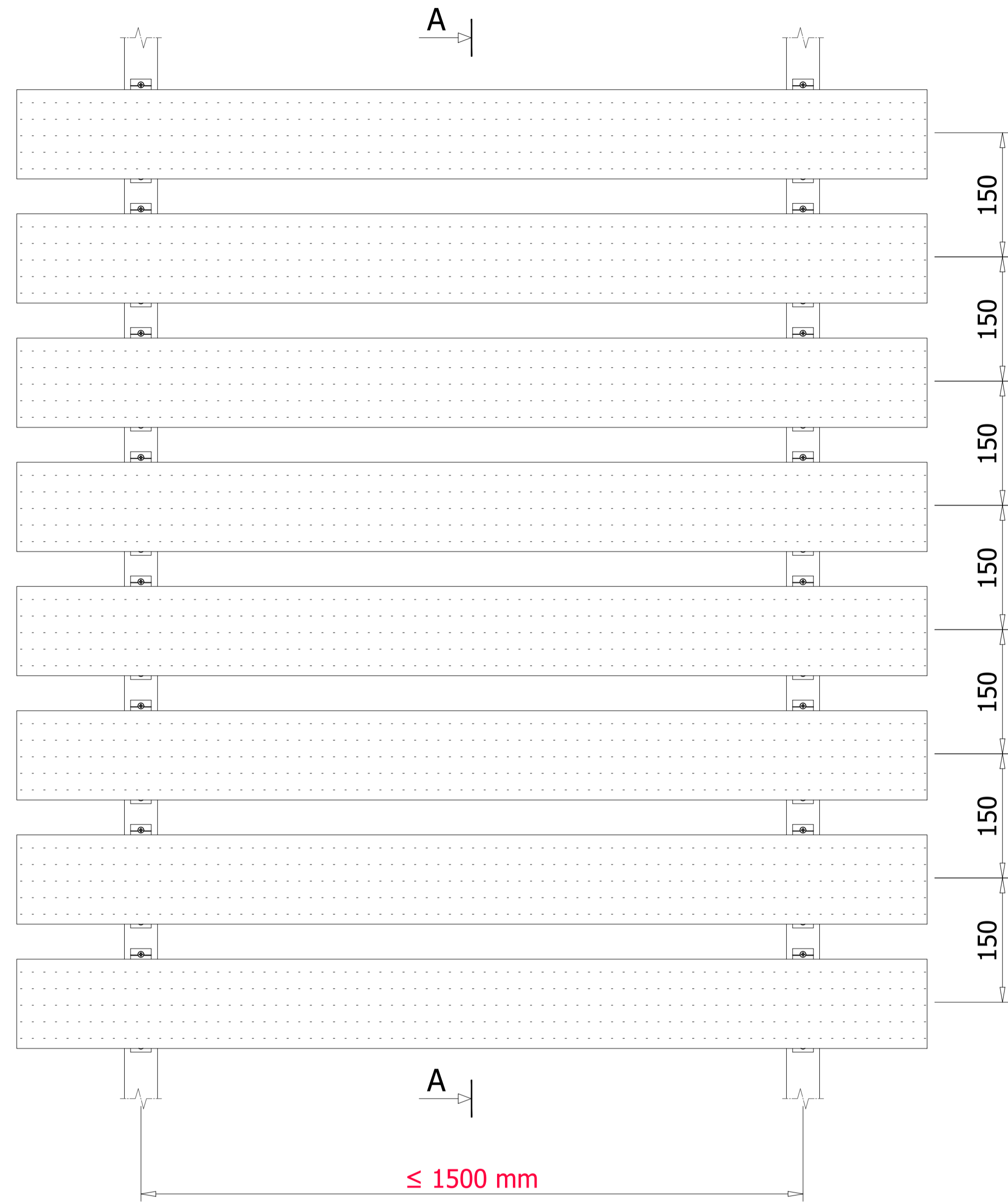

TYPICAL SECTION/ MẶT CẮT ĐIỂN HÌNH

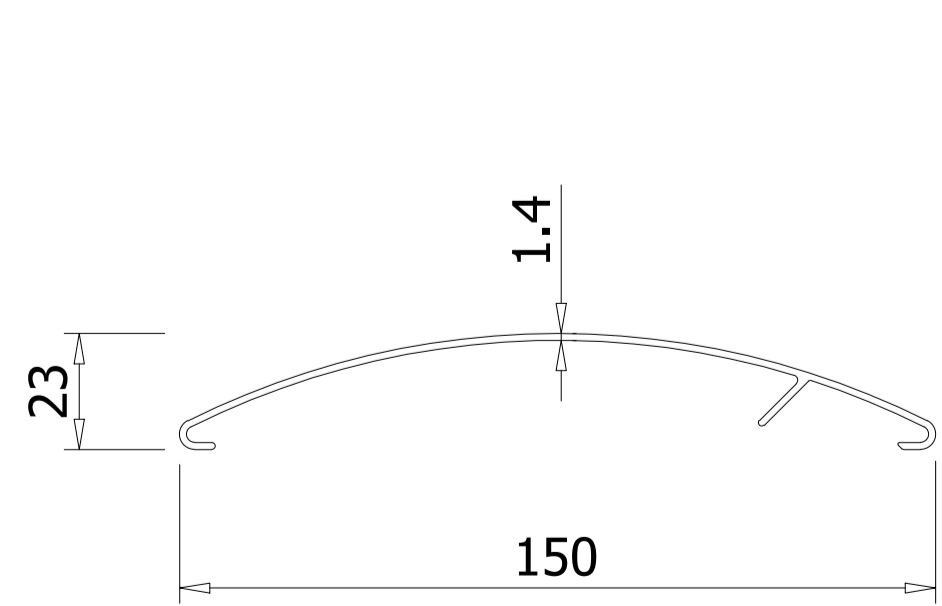

ASC P150 profile

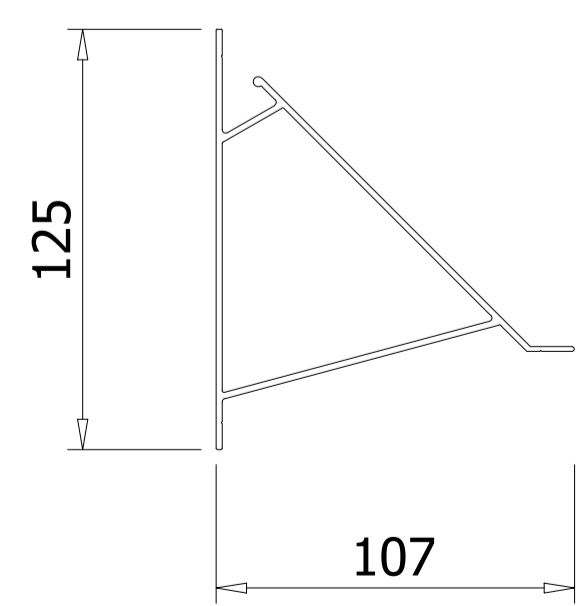

Bracket/ Móc cài lam

SECTION/ MẶT CẮT: A - A

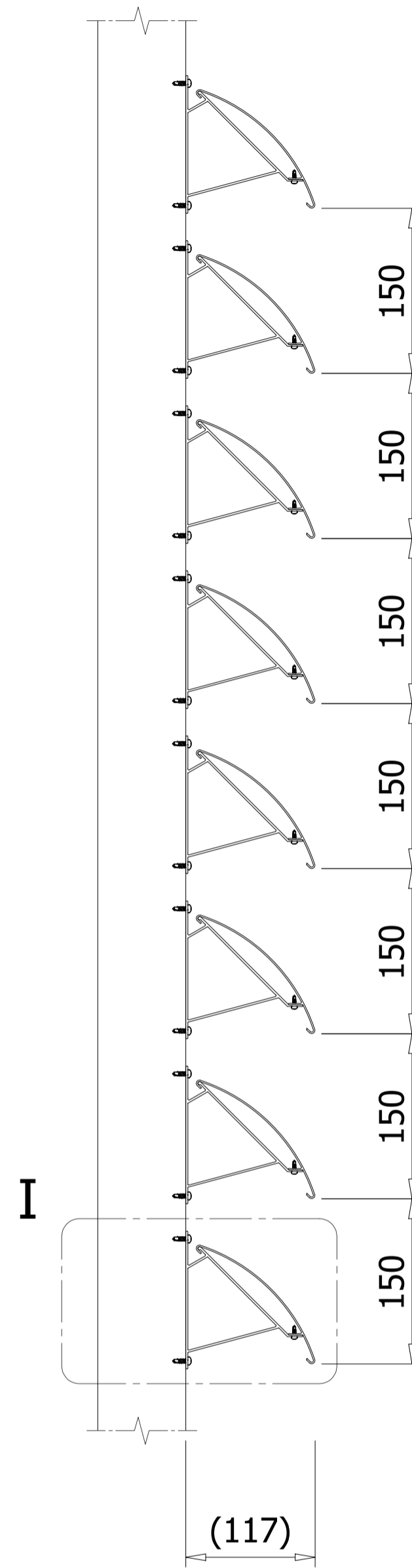

VIEW/ THEO: I

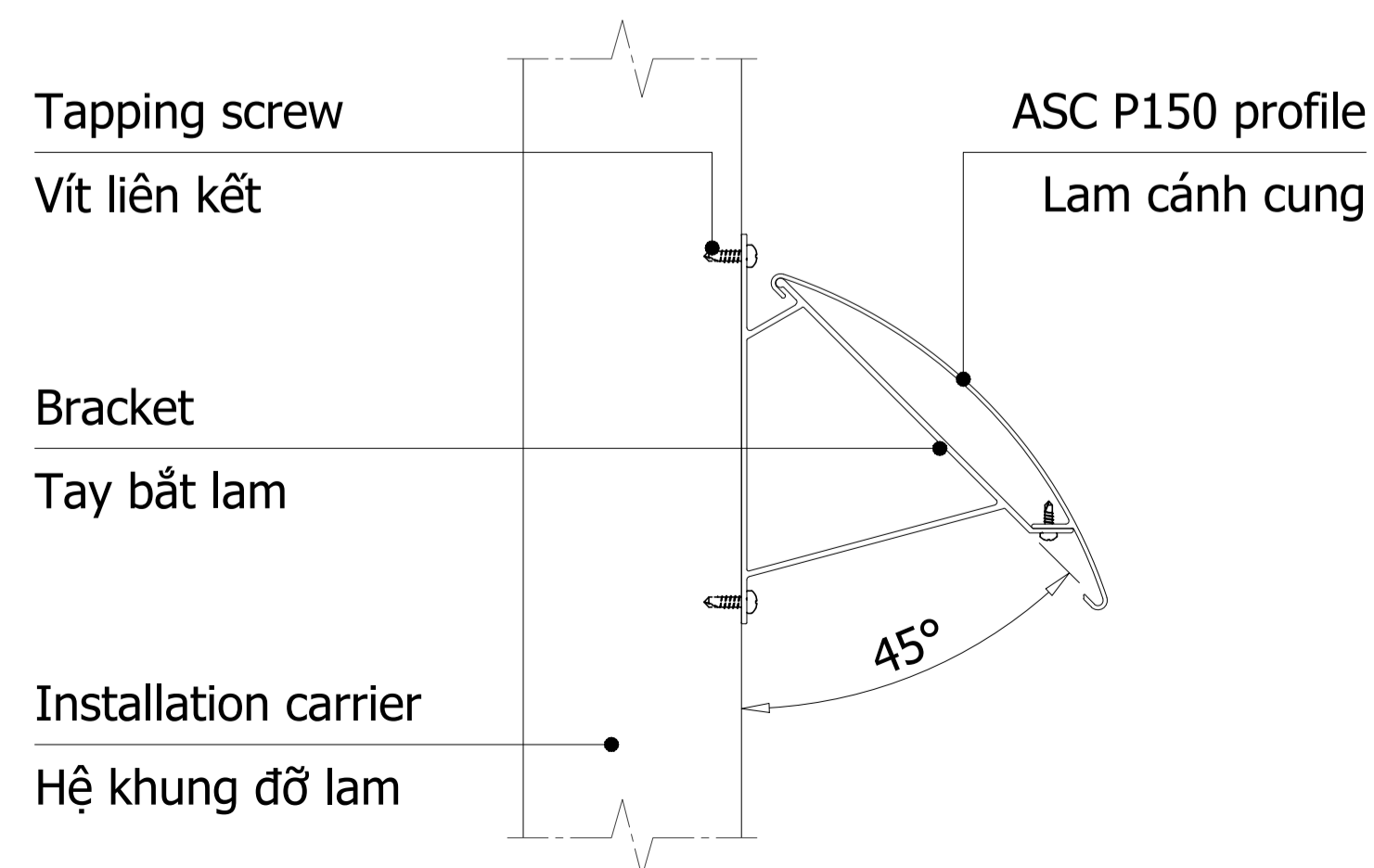

HORIZONTAL PROJECTION SYSTEM
CẤU TẠO HỆ LAM THEO CHIỀU NGANG

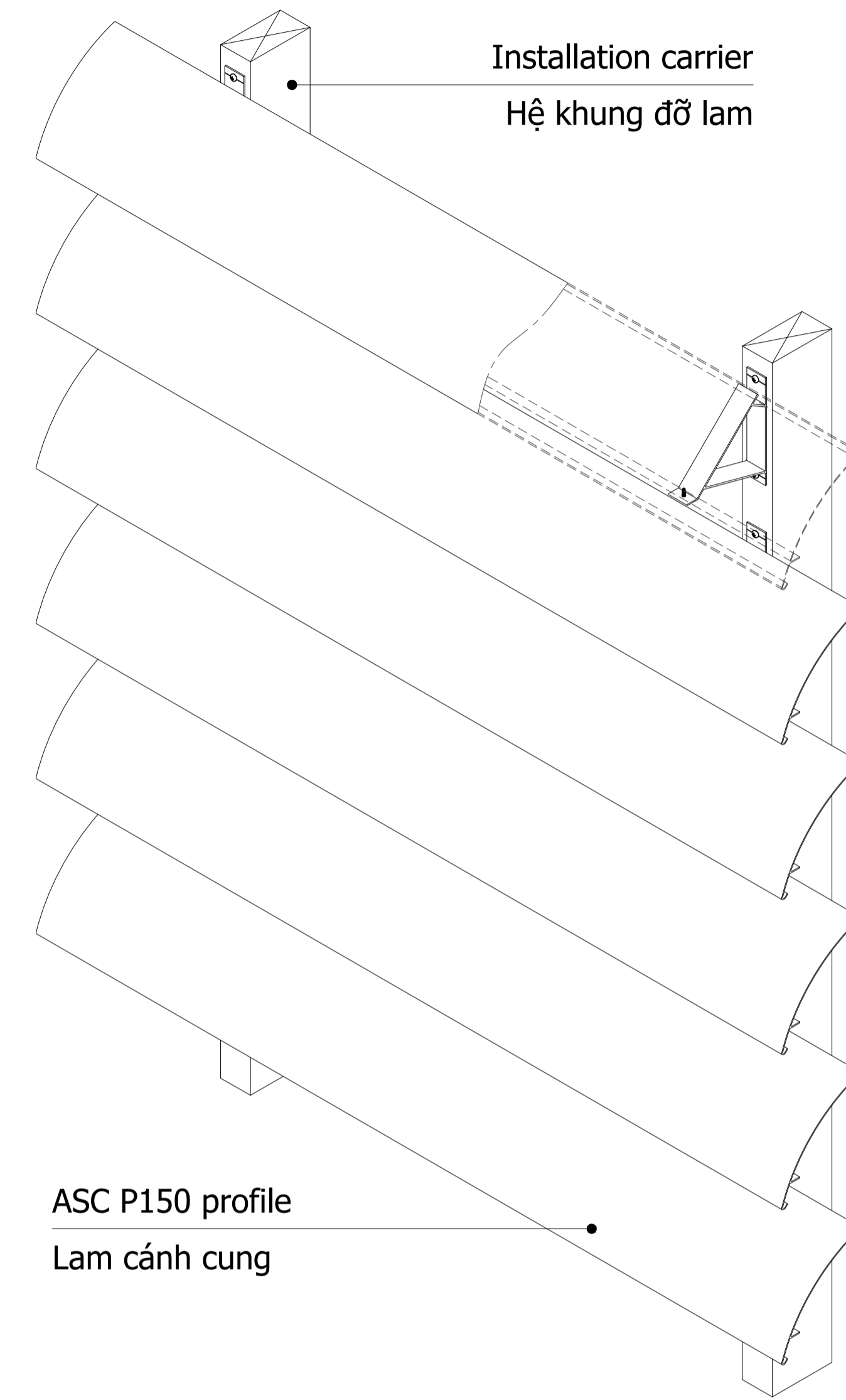

ASC P150 profile
Lam cánh cung

Sun louver and bracket - Technical standards:

- + Material: Aluminum alloy A6063 T5
Certificate: ASTM B221/B221M-21
Certificate: JIS H 4100:2022
Certificate: QCVN 16:2019/BXD
- + Profile length: Customized
- + Surface treatment: Powder coating (color upon request)

Lam chắn nắng và tay đỡ - Tiêu chuẩn kỹ thuật:

- + Vật liệu: Nhôm hợp kim mác A6063 T5
Chứng nhận đạt tiêu chuẩn: ASTM B221/B221M-21
Chứng nhận đạt tiêu chuẩn: JIS H 4100:2022
Chứng nhận hợp chuẩn, hợp quy: QCVN 16:2019/BXD
- + Chiều dài thanh lam: Theo yêu cầu
- + Bề mặt hoàn thiện: Sơn tĩnh điện (màu theo yêu cầu)

Revisions		
No	Date	Description

Owner: _____

Project: _____

Category: _____

Location: _____

Contractor:
Austrong Group
Ceiling - Sun Louver - Façade
Hanoi - Office:
No 49 Ln 15 An Duong Vuong Road, Phu Thuong Ward,
Tay Ho District, Hanoi City, Vietnam
Ho Chi Minh - Office:
No 73-75 S3 Road, Tay Thanh Ward, Tan Phu District,
Ho Chi Minh City, Vietnam
Website: www.austrong.com.vn

Function	Name	Signature
Approved	
Checked	Nguyễn Trung Kiên	
Designed	Nguyễn Trung Kiên	

Title Drawing:
**BẢN VẼ SƠ BỘ
HỆ LAM CÁNH CUNG**

Scale	Format
Date	01/2024	A3 (420x297)
Drawing No.	

© This drawing is copyright by AUSTRONG GROUP